



- Colors compliment pinta acoustic's ceiling tiles
- Double web construction for durability
- Versatile and easy to install

## **pinta Ceiling Grid System**

### Product Information

Now you can have a ceiling grid system that blends beautifully with pinta's or standard ceiling tiles. pinta's Ceiling Grid System is offered in colors that complement the HPC coating or natural finish of our HARMONI, CONTOUR® and WHITELINE® Ceiling Tiles as well as our SQUARELINE® Metal Ceiling Tiles, BIOLINE® Wood Ceiling Tiles, PHONSTOP™ Ceiling Tiles and SONEX® Clean Ceiling Tiles. Standard colors include white, almond, grey, satin chrome and black. Custom colors are also available.

Our commercial-quality ceiling grid system features standard 15/16" capped grid face and a double web design for added strength. It is also easy to install.

#### **Part Selections**

- 8' Main runners
- 4' High profile cross-tees
- 2' High profile cross-tees
- 8' Wall angle moldings
- 12' Main runners and wall angle moldings are available special order

#### **Features and Benefits**

- Intermediate ASTM load-bearing capabilities
- Main runners have non-directional bayonet couplings
- Integral cross-tee end tabs for positive locking and easy disassembly
- Stepped-end cross-tee design resists twisting and provides finished appearance
- Components feature hot-dipped galvanized steel web and capped face for superior corrosion resistance
- All components – main runners and high-profile cross-tees – are manufactured from the same metal for superior strength and stability
- Meets or exceeds building code requirements including Seismic Zones 0-2
- Apply in any area where a drop-in ceiling is desired

2601 49th Avenue North  
Suite 400  
Minneapolis, MN 55430  
Toll-Free 1-800-662-0032  
sales@pinta-acoustic.com  
www.pinta-acoustic.com

White ceiling grid system supporting  
WHITELINE® Ceiling Tiles



White ceiling grid system supporting  
HARMONI Ceiling Tiles



Satin chrome grid system supporting  
SQUARELINE® Metal Ceiling Tiles



### Colors

- White
- Almond
- Grey
- Satin chrome
- Black
- Custom colors are available  
*(minimum quantities may apply)*

### Materials

- Hot-dipped galvanized steel
- Painted face
- Sturdy double-web construction
- Standard 15/16" capped grid face

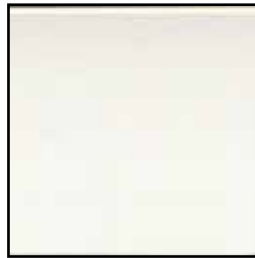
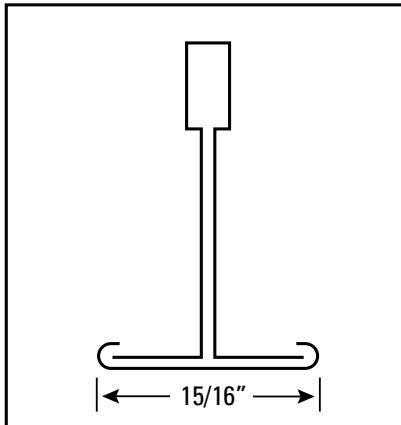

White

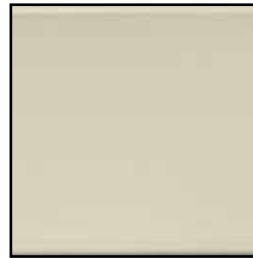

Almond



Black



Grey



Satin Chrome

### Specifications

Product	Length	Nominal Dimensions	
		Height	Face
Main Runners	8'	1 1/2"	15/16"
Cross-tees	2'	1 1/2"	15/16"
	4'	1 1/2"	15/16"
Wall Moldings	8'	7/8"	7/8"

### Other Products

pinta acoustic, inc. manufactures a broad range of acoustical materials including:

- CONTOUR® Ceiling Tiles
- HARMONI Ceiling Tiles
- WHITELINE® Ceiling Tiles
- SQUARELINE® Metal Ceiling Tiles
- BIOLINE® Wood Ceiling Tiles
- SONEX® Baffles and Panels
- SONEX Clean Baffles, Panels and Ceiling Tiles
- FABRITEC Wall Panels
- PHONSTOP™ Ceiling and Wall Tiles
- WHISPERWAVE™ Panels, Baffles, Ceiling Clouds and Awnings
- PROSPEC® Barriers, Foams and Composites
- PROSPEC Decibel Drop™ Viscoelastic Damping Compound
- pinta Ceiling Grid Systems

SECTION 09 53 00  
Ceiling Grid System

PART 1 - GENERAL

1.1 SUMMARY

- A. Section Includes:
  - 1. Painted steel lay-in ceiling grid system.
- B. Related Sections:

EDIT NOTE: ADD OR DELETE SECTIONS PER PROJECT REQUIREMENTS.

- 1. Section 09 53 00 – Acoustical Ceiling Suspension Systems.
- 2. Section 09 21 16 – Gypsum Board Assemblies.
- 3. Division 21 – Fire Suppression.
- 4. Division 23 – Mechanical. Diffusers, vents, and other mechanical items.
- 5. Division 26 – Electrical. Lights and other ceiling mounted electrical items.

1.2 SUBMITTALS

- A. Comply with Section 01 33 00 – Submittal Procedures.
- B. Coordination Drawings: Drawn to scale and coordinating penetrations and ceiling-mounted items. Show the following:

EDIT NOTE: EDIT SUBPARAGRAPHS BELOW TO SUIT PROJECT.

- 1. Ceiling suspension assembly members.
  - 2. Method of attaching hangers to building structure.
  - 3. Ceiling-mounted items including lighting fixtures, diffusers, grilles, speakers, sprinklers, access panels, and special moldings.
- C. Closeout Submittals: Comply with Section 01 77 00 – Closeout Procedures.
    - 1. Operating and Maintenance Manual, including cleaning and maintenance instructions.
    - 2. Extra Material for Owner's stock.

1.3 QUALITY ASSURANCE

- A. Single Source Responsibility: Obtain ceiling grid system for entire Project from a single manufacturer.
- B. Manufacturer's Qualifications: Firm with not less than 5 years experience in manufacturing of products similar in complexity to those required for this Project.
- C. Installer's Qualifications: Firm with not less than 5 years experience in installation of products similar in complexity to those required for this Project, including specific requirements indicated.
  - 1. Successfully completed not less than 5 comparable scale projects.

1.4 DELIVERY, STORAGE, AND HANDLING

- A. Comply with Section 01 60 00 – Product Requirements.
- B. Deliver and store materials in manufacturer's original unopened containers with brands, names, and production lot numbers clearly marked on these containers.

- C. Storage and Protection: Comply with manufacturer's recommendations.
  - 1. Store products in a cool, dry place out of direct sunlight.
  - 2. Protect from elements and from damage.

## 1.5 PROJECT CONDITIONS

- A. Environmental Requirements within building:
  - 1. Grid does not require special environmental conditions.
  - 2. Systems may be installed at any stage of construction.

## 1.6 WARRANTY

- A. Provide manufacturer's written warranty per Section 01 77 00 – Closeout Procedures.

## 1.7 MAINTENANCE

- A. Extra Materials:
  - 1. Deliver not less than the following quantity of each grid system component.

EDIT NOTE: RETAIN AMOUNT OF EXTRA MATERIALS USED ON PROJECT. DELETE THIS ARTICLE OF NO EXTRA MATERIALS REQUIRED OR ACCEPTABLE.

- a. 3 percent.
- b. 5 percent.
- c. 1 carton.
- 2. Furnish Extra Materials from same production run to verify run for color.
- 3. Package replacement materials with protective covering, identified with appropriate labels.

## PART 2 - PRODUCTS

### 2.1 MANUFACTURERS

- A. Subject to compliance with requirements, provide products from the following manufacturer:
  - 1. pinta acoustic, inc.  
2601 49<sup>th</sup> Avenue North, Ste. 400  
Minneapolis, Minnesota 55430  
Telephone: 800-662-0032  
612-355-4250  
Fax: 612-355-4255  
Website: [www.pinta-acoustic.com](http://www.pinta-acoustic.com)  
E-mail: [sales@pinta-acoustic.com](mailto:sales@pinta-acoustic.com)
- B. Substitutions: Comply with Section 01 60 00 – Product Requirements.

### 2.2 SUSPENSION SYSTEM

EDIT NOTE: DELETE SEISMIC OPTION IN PARAGRAPH BELOW IF NOT REQUIRED FOR PROJECT.

- A. Metal Edge Moldings and Trim: Type and profile indicated or, if not indicated, manufacturer's standard moldings for edges and penetrations[ **that comply with seismic design requirements;**] formed from sheet metal of same material, finish, and color as that used for exposed flanges of suspension system runners.
- B. Exposed Grid Suspension Systems – General: Double-web steel suspension system, with main and cross runners roll formed from commercial quality cold-rolled steel sheet, hot-dip galvanized per

ASTM A653/A653M, not less than G30 coating designation, with prefinished metal caps on flanges in widths indicated below.

1. Cap Material: Steel cold-rolled sheet.
2. Cap Finish: Manufacturer's baked polyester finish in color indicated below.
3. System: 15/16 inch (24 mm) exposed Tee grid.
4. Rating: Non-fire-rated.

EDIT NOTE: DELETE THE FOLLOWING COLORS NOT REQUIRED FOR PROJECT.

5. Color: White.
6. Color: Almond.
7. Color: Grey.
8. Color: Satin Chrome.
9. Color: Black.
10. Color: Custom colors available through manufacturer.
11. Acceptable Product: pinta Ceiling Grid System.

### PART 3 - EXECUTION

#### 3.1 EXAMINATION

- A. Verification of Conditions: Examine areas and conditions under which work is to be performed and identify conditions detrimental to proper and or timely completion.
  1. Do not proceed until unsatisfactory conditions have been corrected.

#### 3.2 INSTALLATION

- A. Comply with manufacturer's instructions and recommendations for installation of ceiling grid system:
  1. Coordinate with mechanical and electrical in locating and spacing fixtures, diffusers, and similar items located in ceiling.
  2. Lay out pattern per reflected ceiling drawings. Where not otherwise indicated, lay out in such manner that margins on opposite sides of rooms are equal or greater than 1/2 tile in width.

#### 3.3 CLEANING

- A. Clean adjacent surfaces and remove unused product and debris from site.
- B. After installation is completed, clean soiled surfaces of materials.
- C. Remove and reinstall improperly installed material.
- D. Remove damaged or discolored material, or material that cannot be properly cleaned, and install new material.

END OF SECTION